

Clarke®

weld



MIG/MMA/TIG INVERTER WELDER MODEL NO: MIG270DV MULTI

PART NO: 6015609

OPERATION & MAINTENANCE INSTRUCTIONS



ORIGINAL INSTRUCTIONS

GC09/24

INTRODUCTION

Thank you for purchasing this CLARKE Welder. Before attempting to operate the machine it is essential that you read this manual thoroughly and carefully follow all instructions given. In doing so you will ensure the safety of yourself and that of others around you, and you can also look forward to the welder giving you long and satisfactory service.

SPECIFICATIONS

	MIG270DV Multi	
Unpacked Weight	37kg	
Dimensions (l x w x h) (mm)	855 x 440 x 630 (with base & wheels fitted)	
Power Supply	230V~ 50Hz-1ph	415V~ 50Hz-3ph
Connecting terminals	BS4343(32A)	64A Terminated bare wire ends
Peak Input Power	12 kW	7.9 kW
Max Input Current II Max/II eff	52A	19A
Output Welding Current	MIG 30A-220A MMA 30A-220A TIG 10A-220A	MIG 30A-270A MMA 30A-270A TIG 10A-270A
IP Rating	IP21S	
Insulation Grade	Class 1 - Grade H	
Suitable Electrode size	MMA - 1.6 - 5.0mm TIG - 1.6 - 2.4mm	
Welding Wire size	Steel - 0.8mm, 0.9mm & 1.0mm Aluminium - 1.0 -1.2mm	
Wire spool capacity	5kg /15kg	
Welding Capacity (Mild Steel)	1-12 mm (MIG) 1-15 mm (MMA) 1-5 mm (TIG)	

NOTE: The details and specifications contained herein, are correct at the time of going to print. However, CLARKE International reserve the right to change specifications at any time without prior notice.

PRINCIPLES OF THE MACHINE

The MIG270 Multi is an inverter type welding machine, suitable to carry out Gas and No Gas CO₂ welding, MMA, TIG and MIG. The welder is mainly used for CO₂ gas protected welding which has the advantages of high energy efficiency, strong arc penetration and small welding deformation.

Weldable materials include low carbon steel, low alloy steel, high strength steel, stainless steel and aluminium alloy. Methods include full position spot welding, butt welding, fillet welding and lap welding. The stable welding process can be obtained by using pure CO₂, CO₂+Ar, CO₂+ O₂ and other protective gases. The torch is suitable for wire diameters of 0.8-1.0mm.

Manual Metal Arc (MMA) welding uses a coated, consumable electrode to lay the weld. The arc melts the core of the electrode to produce drops of molten metal (weld pool) to create the welded joint. Because of the versatility and simplicity of MMA welding, it requires less skill and is used primarily to weld iron and steel (including stainless steel). but nickel and copper can also be welded using this method.

MIG (Metal Inert Gas) welding allows you to fuse together two similar metals without altering their properties. A consumable wire electrode is continuously fed through the welding torch fitted with a concentric gas nozzle. the wire is connected to a high voltage supply which creates an electric arc between the electrode (the wire) and the workpiece. The arc is used to create the required heat to turn the metal into a molten state. The wire is used as both the electrode and as a filler.

The gas is used to prevent oxidation and to shield the arc and the weld from atmospheric contamination. The choice of gas is dependent upon the material being welded. This machine is designed to be used for both metal ARC (MMA) and TIG welding.

TECHNICAL FEATURES

This welder adopts IGBT (insulated gate bi-polar transistor) soft switch inverter technology. The single-phase power input, after rectifying, will be converted to 20KHz high frequency AC by IGBT, then the voltage drops after HF transformer, second rectification and filtering to be a welding suitable DC. Through this process, the dynamic response speed of the welded power supply is improved and makes it more compact. The control circuit controls the whole machine so that the welding power supply has good anti-grid fluctuation ability and excellent welding performance.

- The MIG270DV Multi is equipped with high-speed ARM platform, adopting a unique fine waveform control method with low spatter and an elegant weld bead.
- The MIG270DV Multi gives a freely adjustable arc shape with the "Arc Control" knob, and can freely set the inductance of the arc.
- The unique arc starting and burn back control technology greatly improve the arc starting success rate and achieves high-quality fast spot welding.

- Max feeding speed is 24m/min.
- The digitally controlled wire feeding system makes the wire feeding more stable.
- The built-in database with 'synergic' mode makes welding easier.
- The digital operating panel is simple and intuitive. It can display the preset current and voltage and also the actual welding current and voltage.
- The fault error code function diagnoses any faults.

APPLICATIONS

- Welding lower carbon steel.
- Welding, vertical welding, overhead welding, horizontal welding and all position welding.
- Uses 0.8/1.0/1.2 solid wire.
- Acid, alkaline, stainless steel, low hydrogen welding rod when MMA function.

SUITABILITY OF DIFFERENT METHODS

MMA/Arc Welding	Carbon Steel, Low Alloy Steel, Stainless Steel, Cast Iron.
MIG Welding	Carbon Steel, Mild Steel, Stainless Steel, aluminium
TIG Welding	Carbon Steel, Low Alloy Steel, Stainless Steel, Cast Iron, Titanium, Copper + Brass.

Metal Being Welded	Suitable Gas	Part number
Mild Steel	Carbon Dioxide (CO ₂)	6000642
Stainless Steel	Argon	6000663
Aluminium		
Thin sheet metal/Mild Steel	Carbon Dioxide (CO ₂)/Argon Mix	6000662

When using the welder in a gasless configuration the shielding gas is created from the flux within the welding wire.

When using the welder outside you may need to erect a wind break to make sure the shielding gas is not blown away, thereby leaving a poor quality weld.

DUTY CYCLE

This welder is covered by regulations EN 60974-1:2018+A1:2019 / EN 60974-10:2014+A1:2015, where the Duty Cycle is expressed as a percentage of time the machine may be used in a given period for a specified welding current. e.g. When welding at 140 Amps the machine may be used for 6 minutes (60%) in any 10 minute period.

THE MACHINE RATING PLATE

Clarke=weld		Model No.: MIG270DV MULTI		2			
		Part No.: 6015609		3			
4		STANDARD: EN60974-1:2018/A1:2019				5	
6		30A/15.5V~220A/25V (1ph~220V)		30A/15.5V~270A/27.5V (3ph~380V)		10	
		X	45%	100%	60%	100%	
11 $U_1=230V$ $U_0=75V$		I_2	220A	180A	270A	220A	
$U_1=400V$ $U_0=62V$		U_2	25V	23V	27.5V	25V	
8		30A/21.2V~220A/28.8V (1ph~220V)		30A/21.2V~270A/30.8V (3ph~380V)		12	
6		X	45%	100%	60%	100%	
11 $U_1=230V$ $U_0=75V$		I_2	220A	180A	270A	220A	
$U_1=400V$ $U_0=62V$		U_2	28.8V	27.2V	30.8V	28.8V	
6		10A/10.4V~220A/18.8V (1ph~220V)		10A/10.4V~270A/20.8V (3ph~380V)			
		X	45%	100%	60%	100%	
11 $U_1=230V$ $U_0=13.5V$		I_2	220A	180A	270A	220A	
$U_1=400V$ $U_0=13.5V$		U_2	18.8V	17.2V	20.8V	18.8V	
9		$U_1=230/400V$		$I_{1max}=52/19A$	$I_{1eff}=40/15A$		16
		PROTECTION DEGREE: IP21S		INSULATION DEGREE: H			13
1 Imported by		Clarke INTERNATIONAL LEPPING, ESSEX, CM16 4LG, ENGLAND					
		14 7		15			

1	Name/address of manufacturer	9	Energy Supply symbol
2	Model Number	10	Range of Output
3	Part Number	11	Rated No-load Voltage
4	Welding Power Source	12	Conventional Load Voltage
5	British Standards applied	13	Insulation grade
6	Welding Process symbol	14	Rated Supply Voltage
7	Degree of Protection	15	Rated Maximum Supply Current
8	Welding Current symbol	16	Max Effective Supply Current

SAFETY PRECAUTIONS FOR ALL WELDING



WARNING: AS WITH ALL MACHINERY, THERE ARE CERTAIN HAZARDS INVOLVED WITH THEIR OPERATION AND USE. EXERCISING RESPECT AND CAUTION WILL CONSIDERABLY LESSEN THE RISK OF PERSONAL INJURY. HOWEVER, IF NORMAL SAFETY PRECAUTIONS ARE OVERLOOKED, OR IGNORED, PERSONAL INJURY TO THE OPERATOR MAY RESULT.

FAILURE TO FOLLOW THESE RULES MAY RESULT IN SERIOUS PERSONAL INJURY.

GENERAL PRECAUTIONS

BURN PREVENTION

Wear protective clothing - gauntlet gloves designed for use in welding, apron, and protective shoes. Button shirt collar and pocket flaps and wear cuffless trousers to avoid entry of sparks and slag. Wear helmet with safety goggles or glasses with side shields underneath, appropriate filter lenses or plates (protected by clear glass). This is a **MUST** for welding (and chipping) to protect the eyes from radiant energy and spatter. Replace cover glass when broken, pitted, or spattered. Avoid oily or greasy clothing. A spark may ignite them. Hot metal should **NEVER** be handled without gloves. First aid facilities and a qualified first aid person should be available unless medical facilities are close by for immediate treatment of flash burns of the eyes and skin burns. A hard hat should be worn when others work overhead. Flammable hair preparations should not be used by persons intending to weld or cut.

NOTE: ALL protective wear incl. masks & head shields **MUST** comply with PPE Regulation (EU) 2016/425.

TOXIC FUME PREVENTION

Severe discomfort, illness or death can result from fumes, vapours, heat, or oxygen enrichment or depletion that welding (or cutting) may produce. Prevent them with adequate ventilation. **NEVER** ventilate with oxygen. Lead-, cadmium-, zinc-, mercury- and beryllium-, bearing materials, when welded (or cut) may produce harmful concentrations of toxic fumes. Adequate local exhaust ventilation must be used, or each person in the area as well as the operator must wear an air- supplied respirator. For beryllium, both must be used. Metals coated with or containing materials that emit toxic fumes should not be heated unless coating is removed from the work surface, the area is well ventilated, or the operator wears an air-supplied respirator. Work in a confined space only while it is being force ventilated and, if necessary, while wearing an air-supplied respirator. Vapours from chlorinated solvents can be decomposed by the heat of the arc (or flame) to form PHOSGENE, a highly toxic gas, and other lung and eye irritating by-products. The ultraviolet (radiant) energy of the arc can also decompose trichloroethylene and perchloroethylene vapours to form phosgene. **DO NOT WELD** where solvent vapours can be drawn into the welding

atmosphere or where the radiant energy can penetrate to atmospheres containing even minute amounts of trichloroethylene or perchloroethylene.

FIRE AND EXPLOSION PREVENTION

Causes of fire and explosion are:

1. Combustibles reached by the arc, flying sparks, hot slag or heated material;
2. Short circuits.

BE AWARE that flying sparks or falling slag can pass through cracks, along pipes, through windows or doors, and through wall or floor openings, out of sight of the goggled operator.

To prevent fires and explosion keep equipment clean and operable, free of oil, grease, and (in electrical parts) of metallic particles that can cause short circuits. If combustibles are in the area, **DO NOT** weld. Move the work if practicable, to an area free of combustibles.

Avoid working in paint spray rooms, dip tanks, storage areas, ventilators. If the work cannot be moved, move combustibles away from sparks and heat; or protect against ignition with suitable fire-resistant covers or shields.

Walls, ceilings, and floor near work should be protected by heat resistant covers or shields. A Fire Watcher must be standing by with suitable fire extinguishing equipment during and for some time after welding or cutting if:

1. Appreciable combustibles (including building construction) are within 10m.
2. Appreciable combustibles are further than 10m, but can be ignited by sparks.
3. Openings (concealed or visible) in floors or walls can expose combustibles to sparks.
4. Combustibles adjacent to walls, ceilings, roofs or metal partitions can be ignited by radiant or conducted heat.

After work, check that area is free of sparks, glowing embers and flames. An empty container that held combustibles or that can produce flammable or toxic vapours when heated, must never be welded on or cut, unless the container has first been cleaned. This includes a thorough steam or caustic cleaning (or a solvent or water washing, depending on the combustible's solubility) followed by purging and inerting with nitrogen or carbon dioxide, and using protective equipment.

Water filling just below the working level may substitute for inerting.

A container with unknown contents should be cleaned (see paragraph above). **DO NOT** depend on sense of smell or sight to determine if it is safe to weld or cut. Hollow castings or containers must be vented before welding as they can explode.

In explosive atmospheres, **NEVER** weld or cut where the air may contain flammable dust, gas, or liquid vapours.

DO NOT overload arc welding equipment. It may overheat cables and cause a fire. Loose cable connections may overheat or flash and cause a fire. **NEVER** strike an arc on a cylinder or other pressure vessel. It creates a brittle area that can cause a violent rupture or lead to such a rupture later under rough handling.

ELECTRIC ARC WELDING (MMA)

Comply with all precautions in the above and this section. Arc welding, properly done, is a safe process but a careless operator invites trouble. The equipment carries high currents at significant voltages. The arc is very bright and hot. Sparks fly, fumes rise, ultraviolet and infrared energy radiates and work pieces are hot. The wise operator avoids unnecessary risks and protects himself and others from accidents.

BURN PROTECTION

The welding arc is intense and visibly bright. It's radiation can damage eyes, penetrate lightweight clothing, reflect from light coloured surfaces and burn the skin and eyes. Skin burns resemble acute sunburn, those from gas - shielded arcs are more severe and painful.

PROTECTIVE CLOTHING (PPE) MUST BE WORN

Wear long sleeved clothing (particularly for gas shielded arc) in addition to gloves, apron and strong shoes. As necessary, use additional protective clothing such as leather jacket or sleeves, flame-proof apron, and fire-resistant leggings. Avoid outer garments of untreated cotton. Bare skin protection: Wear dark substantial clothing, Button collars closed to protect the chest and neck and button any pockets to prevent entry of sparks.

EYE AND HEAD PROTECTION

Protect your eyes from exposure to the arc. **NEVER** look at an electric arc without protection. A welding helmet or shield containing an appropriate filter plate must be placed over the face before striking an arc. Protect the filter plate with a clear cover plate. A cracked or broken helmet or shield should NOT be worn; radiation can pass through to cause burns.

Cracked, broken, or loose filter plates must be replaced IMMEDIATELY. Replace a clear cover plate when broken, pitted, or spattered. WE SUGGEST you wear flash goggles with side shields under the helmet, to give some protection to the eyes should the helmet not be lowered over the face before an arc is struck. Looking at an arc momentarily with unprotected eyes (particularly high intensity gas-shielded arc) can cause a retinal burn that may leave a permanent dark area in the field of vision. Before welding whilst wearing contact lenses, seek advice from your optician.

PROTECTION OF NEARBY PERSONNEL

For production welding, a separate, well vented room or enclosed bay is best. In open areas, surround the operation with low reflective, non- combustible screens or panels. Allow for free air circulation, particularly at floor level. Provide face shields for all

persons who will be looking directly at the weld. Others working in the area should wear flash goggles. Before starting to weld, make sure that screen or bay doors are closed.

SHOCK PREVENTION

Exposed live conductors or other bare metal in the welding circuit, or in unearthed, electrically-LIVE equipment can fatally shock a person whose body becomes a conductor. **DO NOT STAND, SIT, LIE, LEAN ON, OR TOUCH** a wet surface when welding without suitable protection.

PROTECTION FOR WEARERS OF ELECTRONIC LIFE SUPPORT DEVICES (PACEMAKERS)

Magnetic fields from high currents can affect pacemaker operation. Persons wearing pacemakers should consult with their doctor before going near arc welding or spot welding operations.

PROTECTION AGAINST SHOCK

Keep your body and clothing dry. **NEVER** work in damp area without adequate insulation against electric shock. Stay on a dry duckboard or rubber mat when dampness or sweat can not be avoided. Sweat, sea water, or moisture between body and an electrically LIVE part - or earthed metal - reduces the body surface electrical resistance, enabling dangerous and possibly lethal currents to flow through the body.

EARTHING THE EQUIPMENT

When arc welding equipment is earthed according to the National Electrical Code and the workpiece is earthed, a voltage may exist between the electrode and any conducting object.

Examples of conducting objects include, but are not limited to, buildings, electrical tools, work benches, welding power source cases, workpieces, etc. **NEVER** touch the electrode and any metal object unless the welding power source is off. When installing, connect the frames of each unit such as welding power source, control, work table, and water circulator to the building earth. Conductors must be adequate to carry earth currents safely. Equipment made electrically live by stray current may shock, possibly fatally. **DO NOT EARTH** to electrical conduit or to a pipe carrying ANY gas or a flammable liquid such as oil or fuel.

CABLES

Frequently inspect cables for wear, cracks and damage. **IMMEDIATELY REPLACE** those with excessively worn or damaged insulation to avoid possibly lethal shock from bare cable. Keep cables dry, free of oil and grease and protected from hot metal and sparks.

TERMINALS AND OTHER EXPOSED PARTS

Terminals and other exposed parts of electrical units should have insulating covers secured before operation.

SAFETY DEVICES

Safety devices such as interlocks and circuit breakers should not be disconnected or shunted out. Before installation, inspection, or service of equipment, shut off all power and remove line fuses (or lock or red-tag switches) to prevent accidental turning ON of power. **DO NOT** open power circuit or change polarity while welding. If, in an emergency, it must be disconnected, guard against shock burns, or flash from switch arcing. Always shut OFF and disconnect all power to equipment. A power disconnect switch must be available near the welding power source.

PREPARATION OF THE WORKING AREA



WARNING: ELECTRIC SHOCK CAN BE FATAL. A PERSON QUALIFIED IN FIRST AID SHOULD ALWAYS BE PRESENT IN THE WORKING AREA. IF PERSON IS UNCONSCIOUS AND ELECTRIC SHOCK IS SUSPECTED, DO NOT TOUCH THE PERSON IF HE OR SHE IS IN CONTACT WITH THE WELDER OR CABLES. DISCONNECT THE WELDER FROM THE POWER SUPPLY AND THEN USE FIRST AID. DRY WOOD OR OTHER INSULATING MATERIAL CAN BE USED TO MOVE CABLES, IF NECESSARY, AWAY FROM THE PERSON.

The working area must be sufficiently spacious, with low humidity and good ventilation as to avoid any fumes which develop from the welding process and from incidental material adhering to the pieces to be welded (oils, paints, tars...) which may cause danger to the operator.

Avoid welding any tanks which may contain inflammable residuals.

FURTHER PRECAUTIONS FOR MMA WELDING

1. **ALWAYS** ensure that there is full free air circulating around the outer casing of the machine and that the louvres are unobstructed.
2. A welding arc can seriously damage your eyes. Both operator and spectators must **ALWAYS** use a proper welding face shield or helmet with suitable filter lenses. Proper gloves and working clothes should be worn at all times.
3. **ALWAYS** remove all flammable materials from the welding area.
4. **NEVER** remove any of the panels unless the machine is disconnected from the supply and **NEVER** use the machine with any of the panels removed.
5. **NEVER** use or store in a damp environment. **DO NOT EXPOSE TO RAIN.**
6. **NEVER** attempt any electrical or mechanical repair unless you are a qualified technician. If you have a problem with the machine contact your local CLARKE dealer.
7. **ALWAYS** keep a fire extinguisher handy (Dry Powder, CO₂ or BCF, NOT Water).

8. **NEVER** continue to weld, if, at any time, you feel even the smallest electric shock. Stop welding IMMEDIATELY and **DO NOT** attempt to use the machine until the fault is diagnosed and corrected.
9. **NEVER** allow the earth cable or torch to become wrapped around the operator or any person in the vicinity.

A comprehensive range of CLARKE safety equipment for use when welding is available from your local dealer. See page 45.

Consideration should be given to shielding the supply cable of permanently installed welding equipment, in metallic conduit or equivalent. Shielding should be electrically continuous throughout its length.

The shielding should be connected to the welding power source so that good electrical contact is maintained between the conduit and the welding power source enclosure.

The welding equipment should be routinely maintained according to the manufacturer's recommendations (see page 42). All access and service doors and covers should be closed and properly fastened when the welding equipment is in operation. The welding equipment should not be modified in any way except for those changes and adjustments covered in the manufacturer's instructions. In particular, the spark gaps of arc striking and stabilizing devices should be adjusted and maintained according to the manufacturers recommendations.

ENVIRONMENTAL RECYCLING POLICY













Through purchase of this product, the customer is taking on the obligation to deal with the WEEE in accordance with the WEEE regulations in relation to the treatment, recycling & recovery and environmentally sound disposal of the WEEE.

In effect, this means that this product must not be disposed of with general household waste. It must be disposed of according to the laws governing Waste Electrical and Electronic Equipment (WEEE) at a recognised disposal facility.

If disposing of this product or any damaged components, do not dispose of with general waste. This product contains valuable raw materials. Metal products should be taken to your local civic amenity site for recycling of metal products.

SAFETY SYMBOLS

The following symbols may be displayed on the machine or its packaging.

	Read this instruction booklet carefully before use.		Do not expose to rain.
	Wear welding mask		Recycle unwanted materials under WEEE Directive
	Wear protective gloves		General Hazard
	Wear a dust mask		Warning;- Magnetic field created
	Caution:- Hot surface		Danger! Harmful fumes
	Risk of Electric Shock		Do not weld near flammable or combustible materials
	May interfere with pacemakers		Danger:- Arc Rays

ELECTRICAL CONNECTION



WARNING! READ THESE ELECTRICAL SAFETY INSTRUCTIONS THOROUGHLY BEFORE CONNECTING THE PRODUCT TO A POWER SUPPLY. THE INSTALLATION OF THIS APPLIANCE SHOULD BE CARRIED OUT BY A COMPETENT ELECTRICIAN AND BE IN ACCORDANCE WITH CURRENT IEE WIRING REGULATIONS (BS4343).

IMPORTANT: This product requires a 64A power supply which may make it unsuitable for some users. This is a dual voltage machine for connection to either 230 or 400V.

The welder **MUST** be connected to a 1 phase 50Hz supply through a suitably rated isolator switch. Before switching on, make sure that the voltage of your electricity supply is correct. Connecting it to any other power source may cause damage.

The connecting cable supplied must be connected to the terminals in the rear of the machine in the layout shown. Both 230 and 400V connections are possible, being wired according to the diagrams.

For a 400V connection, the sequence is Red/Brown/Blue as shown, with the earth conductor connected to the terminal to the left of the machine.

For a 230V connection, the sequence is Brown/Blue as shown, with the earth conductor connected to the terminal to the left of the machine.

The protective cover and cable clamp must be used correctly as shown.

If in any doubt, consult a qualified electrician. **DO NOT** attempt electrical connections yourself.

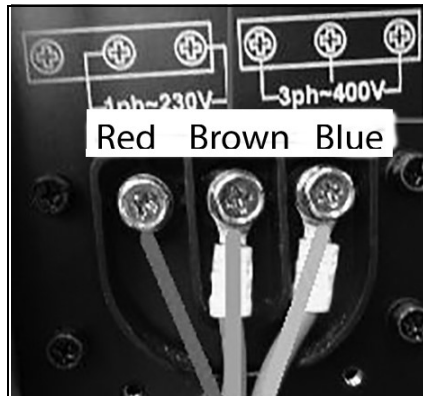

400V connection

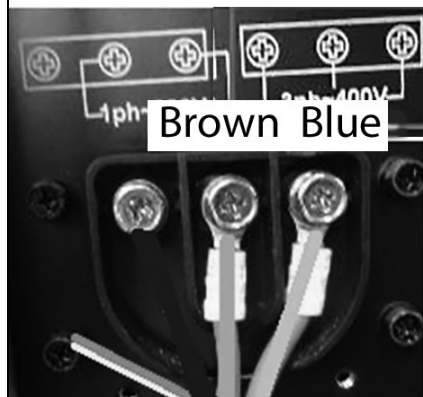

230V connection

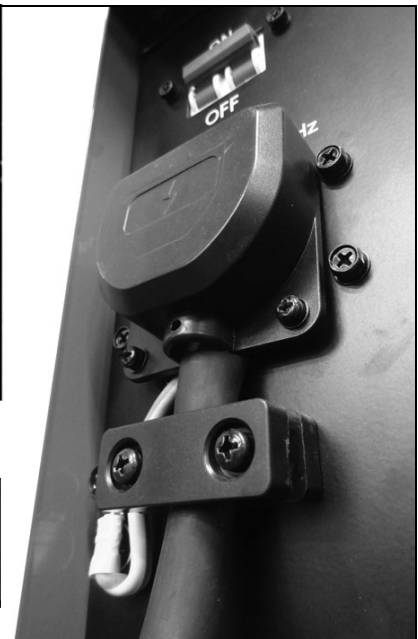

Cable clamp and cover with earth conductor led away to terminal

OVERVIEW OF MACHINE FEATURES

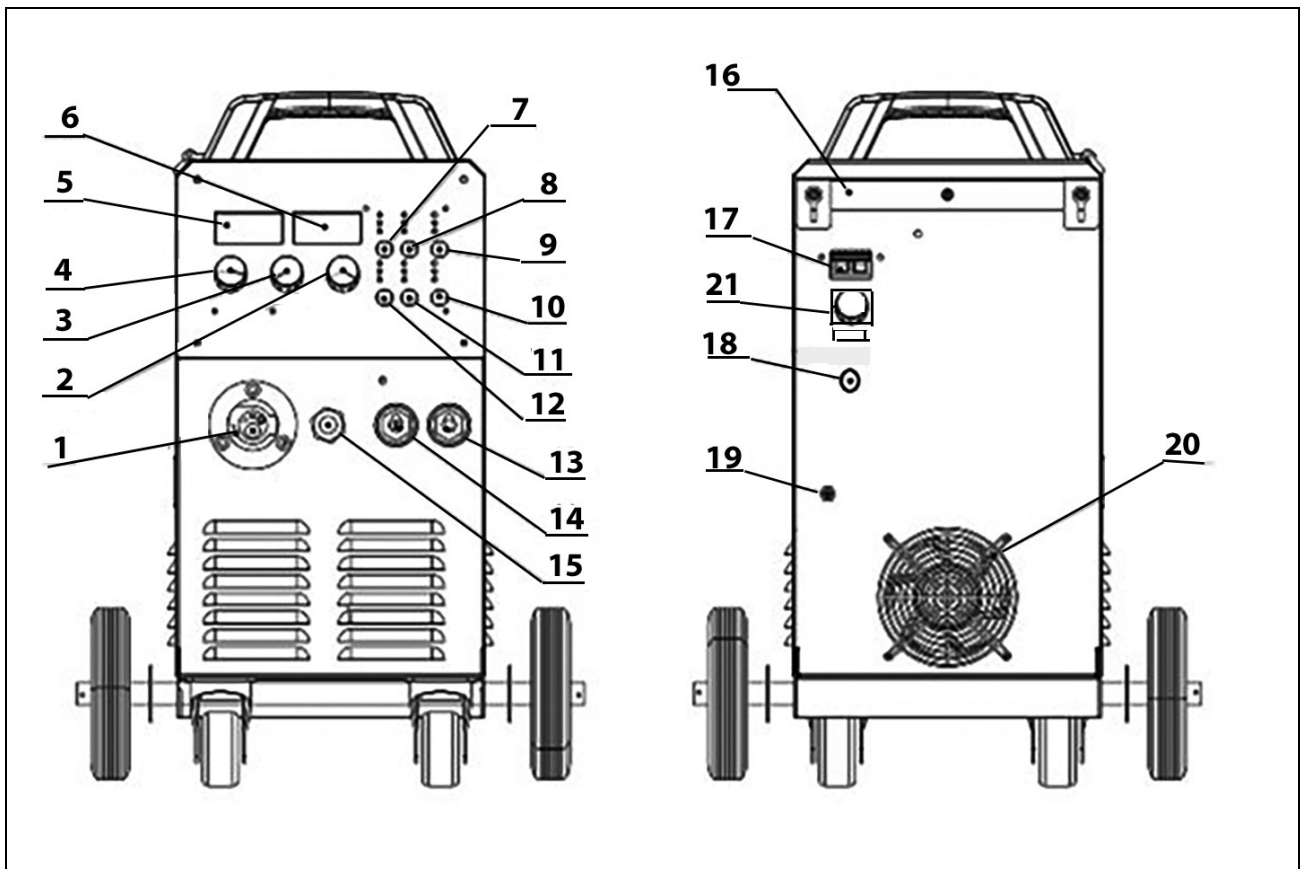

THE CONTROL FUNCTIONS

The MIG270DV Multi-welder is fitted with the following features:

1) TORCH CONNECTION

(2) ARC CONTROL

This knob controls the output characteristics of the arc. Rotating clockwise, the arc is soft, deeper penetration and smaller spatter, but with weak stability. Rotating anticlockwise, the arc is harder, better stability, but penetration depth becomes shallower and the spatter increases. The adjustment range is -5 to +5, and the default position is at 0.

(3) CRATER VOLTAGE/ARC FORCE CURRENT

In MIG/MAG, this knob controls the crater voltage. In MMA, if no remote controller, this knob controls the arc force current.

(4) MIG-WIRE FEEDING SPEED/SYNERGIC WELDING CURRENT WIRE

In MIG/MAG, this knob adjusts the output current value of the welding stage.

In MMA, this knob adjusts the magnitude of welding current.

(5) DIGITAL AMP/FEEDING METER

MIG/MAG: In standby mode, the wire feeding speed is displayed in separate mode, the set current is displayed in Synergetic mode, and the actual current is displayed during welding.

MMA/TIG: display the set current during standby, and display the actual current during welding.

(6) DIGITAL VOLT/ARC LENGTH METER

MIG/MAG: the set voltage will be displayed during standby, and the actual voltage will be displayed during welding.

MMA/TIG: display no-load voltage during standby, and display actual voltage during welding.

(7) SELECTION OF WIRE DIAMETER

The welding power source can be selected from 0.8, 1.0, 1.2 according to the diameter of the welding wire.

(8) SELECTION OF WELDING MATERIALS

Carbon steel CO₂/Flux, carbon steel MAG, and aluminum-magnesium MIG can be selected according to the welding mode.

(9) SEPARATE/ SYNERGETIC SELECTION

Lift-off for operate separate wire feeding and voltage output.

Lift-on for Synergic operation output feeding/Volt, and 2nd knob for micro volt adjustment.

(10) MANUAL WIRE FEEDING

Manual wire inching control.

(11) WELDING MODE SELECTION

MIG, MMA and TIG welding can be selected according to the welding mode.

(12) SELECTION OF WORKING METHODS

Two-step, four-step and special four-step working modes can be selected and the corresponding indicator lights will illuminate.

Two-step working mode: Press the torch switch to start welding normally, and release the switch to stop welding. Suitable for short seam welding.

Four-step working method: After pressing the torch switch to start the arc successfully, you can release the switch to start welding normally. When the torch switch is pressed again, it will switch to the arc end welding specification set by the knob on the front panel and stop welding when the switch is released. Suitable for long seam welding.

Special four-step working method: after pressing the torch switch to start the arc successfully, the welding specification will be welded according to the set initial

welding specification; after releasing the switch, the welding will be performed with the normal welding specification given by the wire feeder; when the welding torch switch is pressed again. After that, it will switch to the set arc welding specification and stop welding when the switch is released.

(13) MACHINE CONNECTION TERMINAL "-" .

(14) MACHINE CONNECTION TERMINAL "+".

(15) FLY-JOINT FOR NEGATIVE AND POSITIVE SELECTION

(16) GAS CYLINDER RETAINER

A strap is also provided to retain the gas cylinder.

(17) SAFETY SWITCH

The main function of this switch is to automatically cut off the power when the machine is overloaded or fails, so as to protect the personal safety of the user and the important parts of the machine. Normally, this switch is moved up to the ON position. The power switch on the local power distribution board (cabinet) should be used as much as possible to start and stop the machine and do not use this switch as a power switch.

(18) POWER CABLE

(19) GAS CONNECTOR

(20) FAN

Cools the heat-generating components in the machine

(21) POWER TERMINAL

The power cable must be connected to the common power terminal according to the voltage to be used.

HIDDEN MENU SETTINGS

1. Press and hold the "Wire Inching" and MIG/MAG MMA TIG Selection Keys" at the same time and restore the factory settings after 5 seconds.

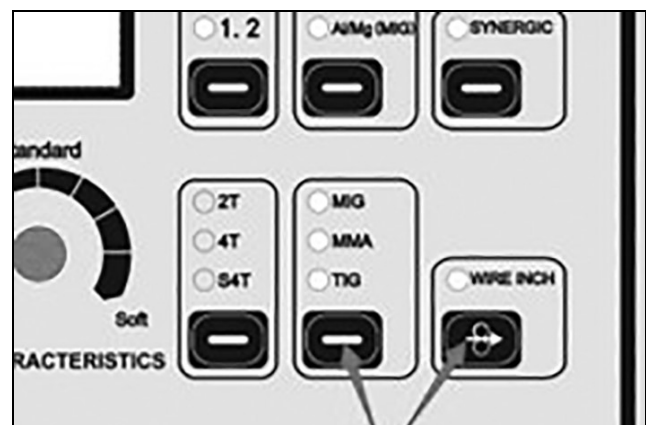

2. Press and hold "Wire Inspection" and "Two-step, four-step special four-step selection key" at the same time to enter and exit the internal function parameters. The meanings of the function parameters are as shown in the following table.

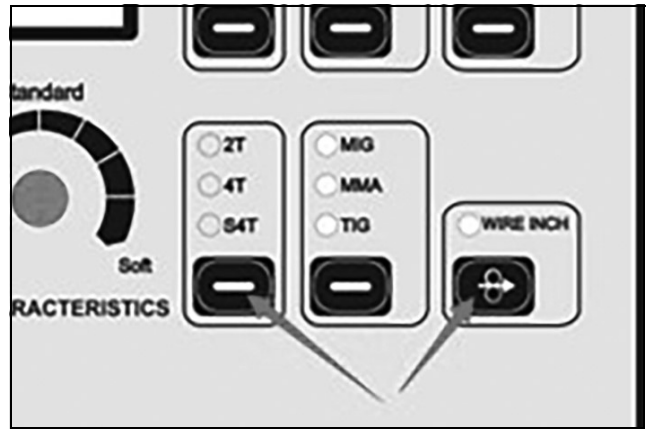

FUNCTION PARAMETERS

	G01	F01	F02	F03	G02
2T	0~5S(0S)	X	X	X	0~10S(2S)
4T	0~5S(0S)	X	X	X	0~10S(2S)
S4T	0~5S(0S)	A:0~200%(125%) V:5~+5(0)	0~10S(0.5S)	A:0~200%(60%) V:5~+5(0)	0~10S(2S)

Remark:

1. Adjustable range (default) : 0~10S(2S)
2. X : Non adjustable
3. F01/F03 : Press "Synergie" to choose AorV

2T AND 4T SETTINGS ARE AVAILABLE AS FOLLOWS:

2T;- Start welding when pressing the torch switch and stop welding upon release. Suitable for short weld beads.

4T: Press the torch switch to start the arc. The switch can be released and the welding is performed normally. When the torch switch is pressed again, it is transferred to the crater welding specification set by the front panel knob and welding will stop when the switch is released. Suitable for a long weld bead.

S4T - Default setting of arcing current and pre-gas support aluminum welding work

No	Functional content	Content set value	Comment	Defaults
G01	Pre-gas	0~5s	Pre-gas setting	OS
F01- only S4T	Starting current and arc length setting	Starting current A:0~200% Arc length V:5~+5	Base on output current 0-200%; Under F01, press "Synergic" change to arc length control	A:125%
F02- only S4T	Down slop time	0~5s	Output current go to crater current time	0.5S
F03- only S4T	Crater current	A:0~200% V:5~+15	Base on output current 0-200%; Under F01, press "Synergic" change to arc length control	A:60% V:0:0
G02	Post gas(s)	0~10s	After welding, continue gas shield protection	2S

PREPARING THE MACHINE FOR USE

LOOSE ITEMS SUPPLIED

When unpacking, any damage or deficiency should be reported to your CLARKE dealer immediately.

- 1 x MB 25AK welding torch with hose (0.8mm tip fitted)
- 1 x Electrode holder/lead
- 1 x Earth cable/clamp
- 1 x Set U rollers U1.0/1.2mm (Aluminium welding)
- 2 x Hose clips
- 1 x Gas hose
- 1 x 1.0mm welding torch tip
- 1 x 1.2mm welding torch tip
- 1 x 1.0mm welding torch tip (aluminium wire)
- 1 x 1.2mm welding torch tip (aluminium wire)
- 1 x PTFE liner
- 1 x Gas cylinder retaining strap
- 2 x Castor wheels with fittings
- 1 x Baseplate
- 2 x Large wheels with axle and pins

FITTING THE GAS BOTTLE HOLDER AND WHEELS

1. Fit both wheels to the stub axles and secure with the cotter pins supplied.
2. Attach the lower panel/gas bottle support to the underside of the machine using the four bolts supplied.

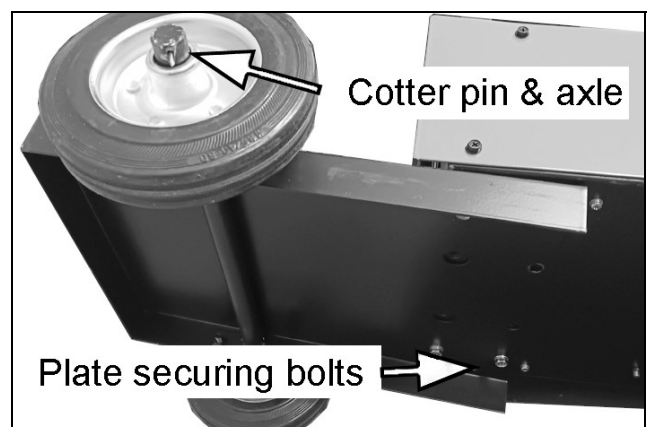

- Using the bolts supplied, secure the two front castors to the underside of the machine.

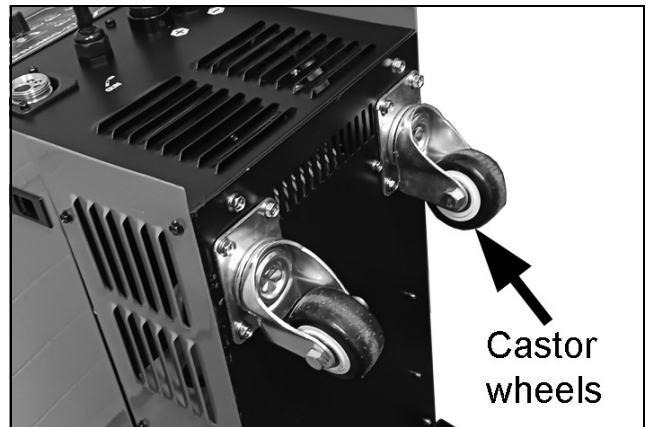

- Mount the gas cylinder retaining bracket to the end of the machine with the securing bolt.
- Mount the gas cylinder to the rear of the machine, securing with the retaining strap. Install a pressure relief valve to the gas cylinder and ensure it is tight to prevent leakage.

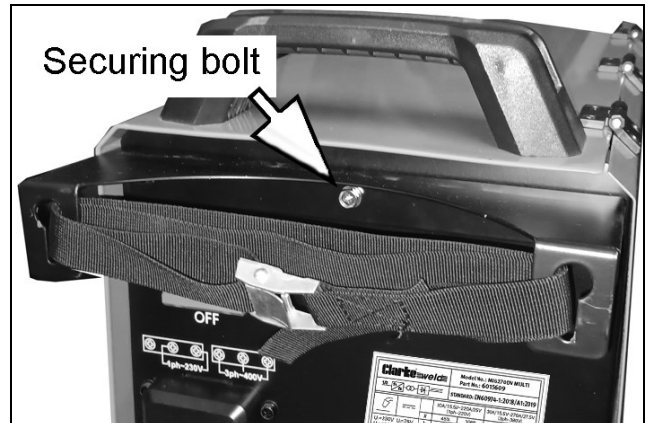

CONNECTING THE GAS CYLINDER

The welder can be configured to weld, with or without a gas supply according to the type of welding wire being used.

- Mild steel solid core (with gas)
 - Flux cored (no gas)
- Connect a gas cylinder to the connector at the back of the welder using the gas hose and hose clips supplied.

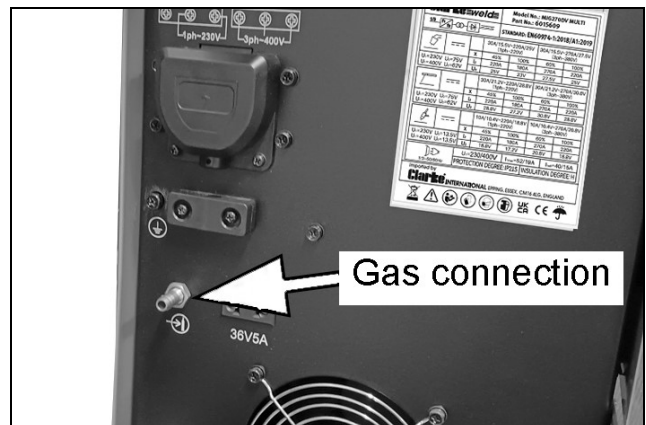

MOUNTING THE WELDING WIRE SPOOL

Select the appropriate wire diameter (0.8, 1.0 or 1.2) according to the welding process anticipated. After the wire diameter is selected, check that the wire diameter matches the size of the wire feeding roller and the welding torch components.

Spools of welding wire are available from your CLARKE dealer.

1. Open the side panel and remove the locking nut.
 - The retaining locknut nut has a left-hand thread.
2. Place a spool of welding wire over the spindle.
 - DO NOT release the tension on the wire as it will unravel, causing feeding problems later.
 - The wire will feed off the spool anticlockwise from the bottom of the reel.
 - The spool must be fitted in the correct orientation otherwise it will not feed correctly.
3. Replace the retaining nut to secure the spool.



SETTING THE DRIVE ROLLER SIZE

1. Release the tensioning handle and hinge it towards you.
2. Lift up the arm.
3. Unscrew each knurled knob and remove it in order to pull off the guide rollers.
 - The groove size is stamped on the corresponding side of the roller.
4. Select the groove size according to the size of the wire you are using and put the roller back on the spindle with your chosen side facing you.
5. Replace the chosen roller onto the spindle. Secure with the knurled knob and re-tension the locking handle.

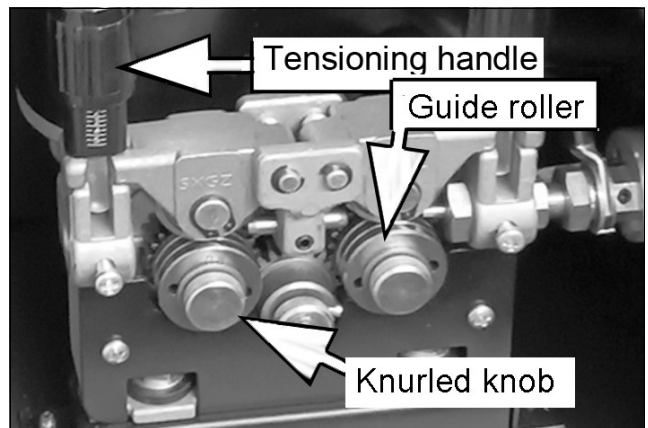

THREADING THE WIRE



WARNING: NEVER OPERATE THIS MACHINE WITH THE SIDE PANELS PARTIALLY OPENED OR REMOVED.

IMPORTANT: Do not release the tension on the wire spool as it will unravel causing feeding problems later.

1. Pull out the end of the wire from the spool, taking care not to release the tension.

- We recommend you cut off and discard the first 10 cm of wire from the spool to avoid any burrs and then straighten the next few centimetres of wire to help with feeding.
2. Loosen the tensioning levers and pivot towards you.
 3. Feed the wire through the guides, over the drive roller and into the torch liner.
 - Push about 10-15 cm into the torch liner.
 4. Lower and reset the tensioning handles.
 - Tighten the tensioning handles sufficiently to hold in position, but do not fully tighten.

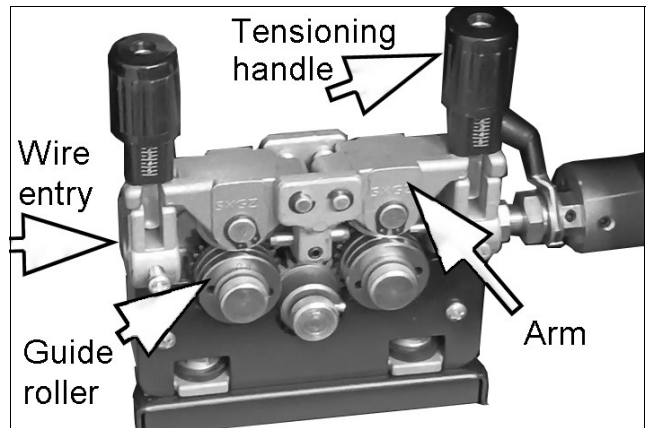

NOTE: Correct tension will allow the wire to feed into the torch liner smoothly but will allow the drive roller to slip in the event of a blockage.

Adjust the pressure handles so that the pressing force is appropriate, the welding wire is normally feeding and there is no slip on the wire feed rollers

RECOMMENDED PRESSURES	
Wire Dia	Reference Adjustment Scale
1.2	4 - 5
1.0	3 - 4
0.8	2 - 3

1) The shaft of the wire spool is equipped with a damping adjustment mechanism incorporating an adjustment bolt at its centre.

FITTING A WELDING ROD

Select the appropriate welding rod and insert it into the welding rod holder.

- It should be approximately the same thickness as the work-piece being welded.

BEFORE STARTING WORK



WARNING: WHEN WELDING ALWAYS ENSURE THERE IS ADEQUATE VENTILATION IN THE WORK AREA DUE TO TOXIC FUMES.

WARNING: DO NOT STRIKE THE ELECTRODE ON THE WORKPIECE, AS THIS MAY DAMAGE THE ELECTRODE.

WARNING: WELDING ARCS PRODUCE HARMFUL UV/IR LIGHT WHICH CAN SERIOUSLY DAMAGE YOUR EYES. ALWAYS USE A WELDING FACE-SHIELD WITH A SUITABLE FILTER THAT CONFORMS TO CURRENT STANDARDS.

WARNING: PROTECT BYSTANDERS BY USING WELDING SCREENS.

WORKING SPACE

The welder should be used indoors away from direct sunlight, rain, low humidity or airborne dust. Ideally, the surrounding air temperature should be in the range of 10 to 40 degrees C.

Welding should be done in a windless place (use of a wind shield, etc. if necessary). Make sure that there is at least 20cm of space around the welder to ensure good air cooling.

ALWAYS position the machine on level ground.

CONNECTION OF ATTACHMENTS

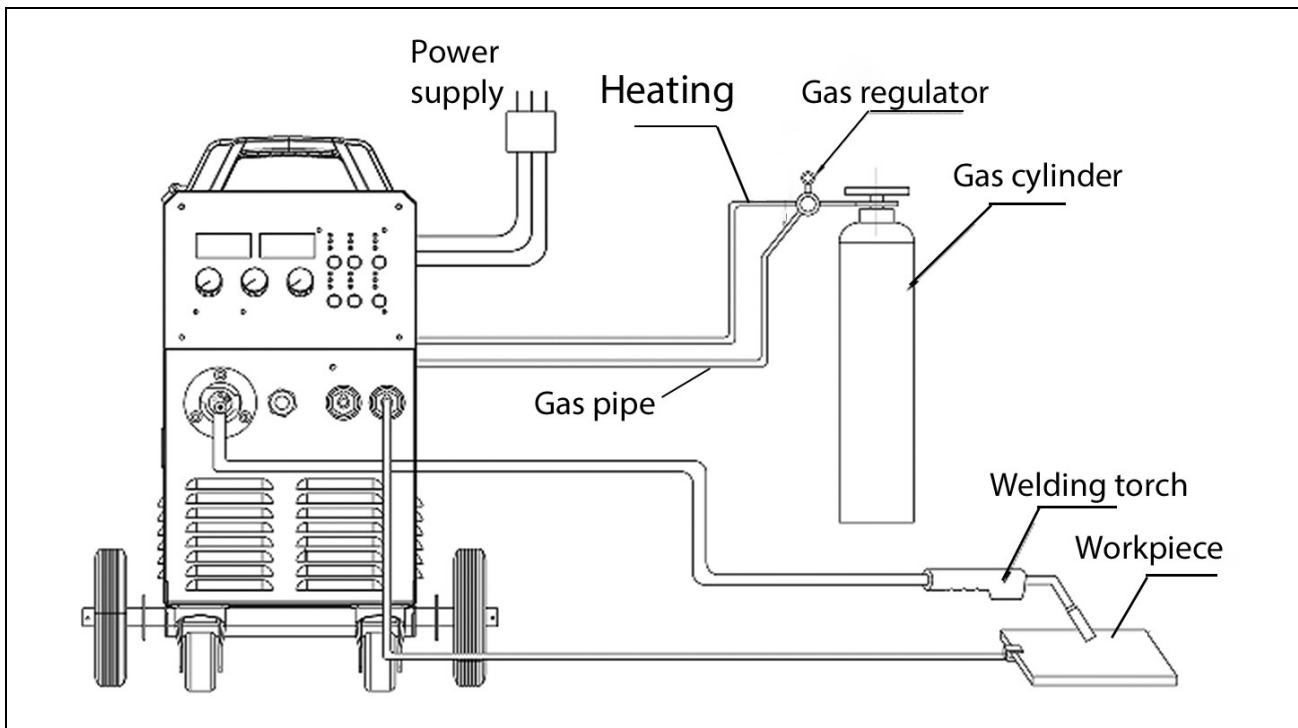

Cables and gas supply must be connected as shown.

CONNECTION AND USE METHOD FOR MANUAL ARC WELDING (MMA)

CONNECTION OF OUTPUT CABLES FOR MANUAL ARC WELDING

There are two ways to connect the power output cable: front connection and reverse connection.

1. Front connection

The workpiece is connected with "+", welding clamp is connected with "-". Manual arc welding is often used to weld acid electrodes. This welding method has higher welding rate and shallower welding depth.

2. Reverse connection

The workpiece is connected with "-", via a welding clamp and is connected with "+". Alkaline electrode welding is often used in manual arc welding. Adopting this welding method, the welding seam is deep. In addition, using an alkaline electrode welding method is good for arc stability.

APPLICATION METHOD OF MANUAL ARC WELDING

1. Turn on the power supply switch of the machine.
2. Set the welding method on the welding power control panel to "MMA" manual arc welding.
3. *Manual arc welding can be carried out only after the output end of the welding power supply is reliably connected with the welding cable. When no remote control box is inserted, the welding current is adjusted by the "welding current" knob on the front panel of the welding power supply. Thrust is regulated by the "thrust current" knob on the front panel of the welding power supply. When a remote control box is inserted, the welding current and thrust force are adjusted by a knob on the remote control box.*

CONNECTION AND OPERATION FOR MMA

There are two connection mode: positive and negative connection.

(1) Positive connection

Connect the workpiece to "+" and the electrode holder to "-". This configuration is often used when welding acid electrodes, giving high deposition rate and shallow penetration.

(2) Negative connection

Connect the work piece to "-" and the electrode holder to "+". This connection is often used for alkaline electrodes. The weld penetration is deep. and good for arc stability when using this negative connection welding alkaline electrodes.

OPERATION USING MMA

1. Set the power ON.
2. Choose " " MMA on the front panel.

MMA welding is possible only after the output of the machine is connected to the welding cable.

CONNECTION FOR GAS SHIELDED WELDING

GAS SHIELDED WELDING CONNECTION

See diagram page 23 for connection between welder and other equipment.

1. Welding power supply and power supply connection

Ensure the machine is connected correctly to the power supply as described on page 13.

2. Connection of welding power supply and welding gun.

Insert the torch into the torch socket on the front panel.

When using solid cored wire, connect the electrode gun polarity conversion joint to the "+" machine connection.

When using flux-cored self-protecting welding wire, connect the polarity conversion joint of welding gun to the "-" end of the machine connection.

3. Welding power supply and workpiece connection.

When using solid cored wire, connect the connector of the earthing cable with the "-" connection and the other end of the earthing cable is reliably connected with the workpiece.

When using the flux-cored self-protecting welding wire, connect the earth cable with the welding power supply "+", and connect the other end of the earth cable with the workpiece.

4. Connection of gas cylinder and gas regulator

1. Fit the gas regulator to the gas cylinder and tighten to prevent leakage;
2. Insert the two-core plug on the gas regulator into the heating socket on the rear panel of the machine.
3. Connect the pipe terminal on the rear panel with the outlet of the gas regulator with the air pipe and secure it with the hose clamp supplied.

The cylinder should be secured to the cylinder bracket with the strap.

For MAG gas welding, please use gases that meet the MAG welding requirements. When mixing two bottles of gas, a proportioner must be used to avoid uneven mixing.

PREPARATION BEFORE USE OF GAS SHIELDED MIG WELDING

Leather gloves and safety boots should be worn to protect the operator's skin or exposed parts of the body.

Light-blocking filters shall be used to protect the operator's eyes. The principles for selecting filters are shown in the table below.

Welding current	Under 100A	100A-300A	Over 300A
Use of photometric protection	No9 / No10	No11 - No12	No13 - No14

The workplace should be equipped with dust removal equipment to avoid the harmful smoke inhaled by the operator during welding.

SWITCH OPERATION AND GAS FLOW REGULATION

1. Set the power switch to ON.
2. Set the welding method on the control panel to gas welding position.
3. Set the welding wire diameter and protective gas on the control panel at the position of the used wire diameter and gas.
4. According to the welding power control panel switch "gas check" position, turn on the gas cylinder switch, adjust the gas regulator and set the flow-meter value as required.
5. Press the switch "Normal" button on the welding power control panel to stop the gas supply.

WELDING WIRE INSTALLATION

Make sure that the specifications of the wire feeding wheel are the same as the diameter of the welding wire when installed as shown on page 21.

CONNECTION AND OPERATION FOR MIG/MAG

Connect the attachments as shown in the diagram on page 23.

1. Connect the torch to the socket on the front panel.
2. Connect the earth cable" – " on the front panel and ensure a reliable connection between the earth cable and the work piece.
3. Install the gas regulator to the gas cylinder and tighten to prevent leaks.
4. Insert the two-pin plug of the gas regulator into the heating socket on the rear panel.
5. Connect the air pipe of feeder wire to the gas regulator air outlet and secure with the hose clamp supplied.

When in MAG mode a mixed gas suitable for MAG welding can be used. If mixing two bottles of gas, a gas proportioning mixer must be used to deliver an even mixture.

CONFIGURING THE MACHINE CONNECTIONS

1. Switch on using the switch on the rear panel.
2. For Flux or MMA welding, select the appropriate welding rod and fit it into the welding rod holder.

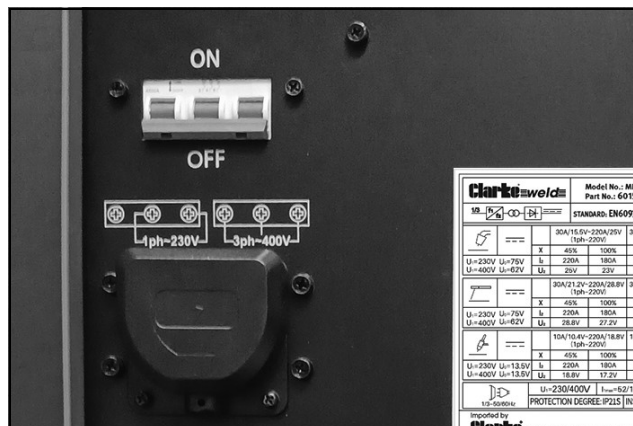

The following sizes can be used and are available from your CLARKE dealer.

	ROD DIAMETER	WORKPIECE THICKNESS
MIG	0.6 mm	1-5 mm
	0.8 mm	
	0.9 mm	
	1.0 mm	
MMA	1.6 mm	1.5 - 2.0 mm
	2.5 mm	2.5 - 3.0 mm
	3.2 mm	3.5 - 4.5 mm
	4.0 mm	4.0 - 5.0 mm
TIG	1.6 mm	1.0 - 2.0 mm
	3.2 mm	3.5 - 4.5 mm
	4.0 mm	4.0 - 5.0 mm

3. Attach the earth clamp to the workpiece as close as possible to the area being welded. Clean with a wire brush where necessary to ensure the connection is as clean as possible.

PREPARING THE WORKPIECE

The area being welded should be perfectly clean. Any coating, plating or corrosion must be removed, otherwise a good weld will be impossible to achieve.

CONTROL SETTINGS

Refer to pages 14- 15 for detailed control panel functions.

1. Turn on the gas regulator of the gas cylinder. The gas pressure will be shown by the gauge.
 2. Turn the gas regulator anticlockwise. Loosen the wire roller while pressing on the torch switch and adjusting the gas flow as required. Check the tension on the wire rollers.
 3. Set the wire size selector control (7) to the wire you have fitted to the machine.
 4. Depress the torch switch until the wire extends to the nozzle.
 5. Set the welding material selector (8) as required.
 6. Set the MIG/MMA/ LIFT TIG function selector to the chosen setting.
 7. Set the Synergic selector (9) as required.
 8. Set the 2-step/four step or four-step working mode (12) as required.
 9. If Synergic is not selected, Set the Welding Current /wire Speed Selector knob (4) to an intermediate setting or according to the size of the weld being performed.
 10. Set the MIG Arc selector knob (3) left or right according to the shape of the weld (either deep/narrow or wide/shallow).
 11. Set the Arc Length control (2) as required.
 12. Confirm the torch and cables are configured as shown on page 23.
- With practice you will gain a feel for the correct current setting for different welding thicknesses.



MACHINE STATUS MESSAGES DISPLAYED

Code	Functions	Details	Description	Default setting
F00	Standard/Fast Feeding mode select	ON/OFF	OFF-standard On-Fast Feeding	OFF
F01	Burn back (s)	5.0~5.0	Burn back time setting	0.0
F02	Slow feeding (m/min)	5.0~5.0	Only control it under F00-OFF	0.0
F03	Pre-gas (s)	0.01-2.00s	Post gas time setting	0.10
F04	Post gas (s)	0.01-2.00s	Post gas time setting	0.50
F05	Start arcing (%)	0-200	Only control it under F00-OFF	125
	Start arc length	-5.0~5.0	Under hidden menu and press "Synergic" control	0.0
F06	Extinguishing arc (%)	0-200	Only control it under F00-OFF	60
	Extinguishing arc	-5.0~5.0	Under hidden menu and press "Synergic" control	0.0
F07	Transition time (s)	0.1-9.9	Only control it under F00-OFF	0.5
F17	Start arcing time	OFF-0.1-9.9	Only control it under F00-OFF and 2-step	OFF
F18	Arc extinguishing time	OFF-0.1-9.9	Only control it under F00-OFF and 2-step	OFF

OPERATING THE WELDER (MIG)

1. With the welding current set and the wire trimmed, set the wire feed control to an intermediate setting.
2. Approach the work with the torch tip at an angle of about 45° and pull the torch trigger fully.
 - As the wire touches the workpiece an arc will be struck.
3. In order to produce a satisfactory weld, the control may be fine tuned as required. This will come with practice.
 - MIG welding is an acquired skill. It is strongly advised that, if you are not fully familiar with this type of welding, you practice on a piece of material with the same characteristics as your workpiece until you are satisfied with the result and you have set your welder to produce a satisfactory weld.
 - One of the problems experienced with novice welders is the welding wire sticking to the contact tip. This is as a result of the wire feed speed being too slow. It is always better therefore to start with too high a speed and back off slightly to avoid the possibility of the wire welding itself to the tip.
 - The speed of wire delivery will increase automatically as the current is increased.
 - Listen to the sound made. An irregular crackling sound denotes too high a wire speed. Decrease the voltage/speed until a regular, strong buzzing sound is heard.

WELDING TECHNIQUE

- Try to maintain the tip of the nozzle at an angle of approx 45° and at a constant distance of approx 5-7mm from the workpiece.
- Try to maintain a constant speed of movement with the torch.
- **DO NOT** weld in windy conditions or in an area where ventilation is a problem, or where air flow fluctuates.
- **ALWAYS** keep the wire and nozzle clean...NEVER use rusted wire.
- Avoid sharp bends or kinks in the welding hose.

THERMAL OVERLOAD

The 'Thermal Overload' shuts off the welder when it becomes too hot, due to the duty cycle being exceeded. This is to prevent any damage to the machine.

When this occurs, the Error Code E19 will be displayed. Allow the welder to cool until the amber light extinguishes before resuming work.

OPERATING THE WELDER (MMA/ARC)

The consumable electrode is connected to a high amperage low voltage supply which creates an electric arc between the electrode and the workpiece.

The most difficult aspect of the arc welding process, particularly for beginners, is that of striking an arc. We strongly recommend that you practice on some pieces of scrap metal to get the feel of the operation before you start an actual welding job.

1. Holding the welding mask close-up to your face, give a short stroke with the electrode on the workpiece. As soon as the arc is primed, withdraw the electrode from the workpiece to leave a gap. The current will flow across the gap with a crackling noise and a brilliant arc. Continue to weld in one direction, maintaining the small gap as you go.
2. As soon as the arc is struck, maintain a distance from the workpiece equal to the diameter of the electrode. Keep this distance as constant as possible for the duration of the weld. As you advance along the workpiece the angle of the electrode must be maintained at between 20° and 30°.

NOTE: When you prime the arc be sure to withdraw the electrode swiftly to leave the gap, otherwise the electrode will weld itself to the workpiece. If this occurs give the electrode a short sharp jerk to free it and, if necessary, prime the arc again. If you cannot free the electrode, switch the machine off immediately and free it. Take care the electrode will get red hot very quickly and will be capable of burning through welding gloves.

3. At the finish of the weld, bring the end of the electrode backward in order to fill the weld crater and then quickly lift the electrode from the weld pool to extinguish the arc.
4. Inspect the job carefully. Any slag forming on the surface should be chipped away with a chipping hammer or pick. ALWAYS wear your safety goggles when chipping away slag.

OPERATING THE WELDER (TIG WELDING)

TIG welding is primarily for very thin materials. It uses a non-consumable tungsten (or tungsten alloy) electrode held in a torch.

A shielding gas (100% Argon), is fed through the torch to protect:

- The electrode
- Molten weld pool
- Solidifying weld metal from contamination by the atmosphere

The electric arc is produced by the passage of current through the conductive, ionized shielding gas. The arc is established between the tip of the electrode and the work. Heat generated by the arc melts the base metal. Once the arc and weld pool are established, the torch is moved along the joint and the arc progressively melts the joined surfaces. Filler wire, if used, is usually added to the leading edge of the weld pool to fill the joint.

This process is ideally suited for welding thin metals such as car body panels, pressure vessels, heat exchangers, pipes etc., where accuracy and a high quality weld is desired, as it produces a very low porosity weld.

MAIN FEATURES OF TIG WELDING

1. Electronic control of welding current.
2. Forced air cooling.
3. A thermal overload protection device prevents overheating.

TIG WELDING PROCESS ADVANTAGES

- It produces superior quality welds, generally free of defects.
- It is free of the spatter which occurs with other arc welding processes.
- It can be used with or without filler metal as required.
- It allows excellent control of root pass weld penetration.
- It can produce welds at high speeds.
- It allows precise control of the welding variables.
- It is capable of welding very thin material (0.5mm), without undue distortion.

LIMITATIONS

1. Greater weld dexterity is required.
2. The DC output is **not suitable** for welding aluminium.

TIG WELDING

Before TIG welding you must obtain the correct torch and a gas cylinder of 100% pure Argon. (see page 45)

To prepare the machine for TIG welding, adopt the following procedure.

1. Plug the work clamp lead in to the +ve terminal, and secure the work clamp to the workpiece.
2. Connect the torch to the -ve terminal
 - For good contact, the work clamp must be attached to clean bare metal. Clean with a wire brush where necessary.
3. Ensure the electrode at the torch nozzle, protrudes by 4 - 5mm. Also ensure that the electrode is sharply pointed with an angle of 40° - 60° if it is not, grind it to shape.
4. Set the welding current for the thickness of the material to be welded and the size of tungsten electrode to be used.
5. If the machine stops at any time and the Error Code E19 is displayed, the thermal overload has intervened. Wait until the welder has cooled sufficiently before restarting work.
6. Cover your face with the head shield, bring the torch to within 3-4mm of the work, and at an angle of 40 - 60° so that the ceramic nozzle gently touches the work surface..

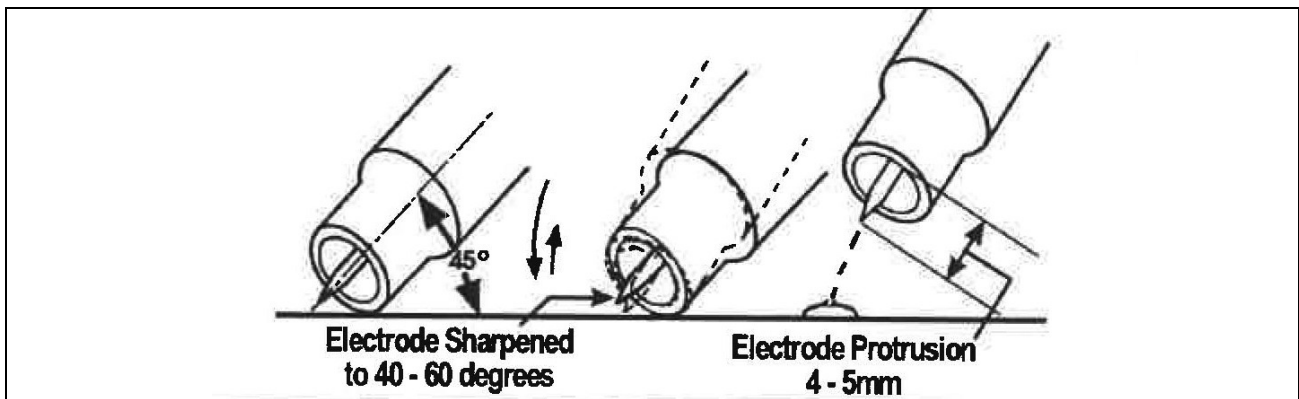

7. Scratch the tip of the electrode against the piece to be welded, as soon as the welding arc starts, remove the electrode to a distance of 3-4 mm, and continue the weld. (See notes below).
 - This method is referred to as 'Scratch Arc'.
8. To stop welding remove the torch from the workpiece.
9. Turn off the gas as soon as you finish welding.

Notes

- To avoid a visible strike mark on the surface of the workpiece it is advisable to strike the arc in the joint where the mark will be concealed by the weld.

- Thin sheet and stainless steel may be welded with or without filler, similar to gas welding.
- The filler is fed in at the edge of the pool. The rod must not touch the tip of the electrode or enter the arc. The end of the rod must always be shielded by the argon atmosphere to prevent as far as possible the formation of oxides of its surface. When welding stainless steel and copper, it is often possible to feed in the filler continuously at the edge of the pool.
- The arc length generally varies between 3 and 6 mm depending on the type of joint, type and thickness of material and so on.
- The torch is advanced in the direction of welding, without lateral movement, maintaining the torch angle of 45° to the workpiece.

(A TIG torch kit is not supplied with the machine. These are available from your CLARKE dealer (Part number 6012232/6012239).

WELDING SETTINGS TABLES

L-SHAPED BUTT WELDING

Metal thickness (mm)	Wire diameter (mm)	Root gap G (mm)	Welding current (A)	Welding voltage (V)	Welding speed (cm/min)	Gas Flow (L/min)
0.8	0.8 - 0.9	0	60-70	16-16.5	50-60	10
1.0	0.8 - 0.9	0	75-85	17-17.5	50-60	10-15
1.2	0.8 - 0.9	0	80-90	17-18	50-60	10-15
1.6	0.8 - 0.9	0	95-105	18-19	45-50	10-15
2.0	1.0 - 1.2	0 - 0.5	110-120	19-19.5	45-50	10-15
2.3	1.0 - 1.2	0.5 - 1.0	120-130	19.5-20	45-50	10-15
3.2	1.0 - 1.2	1.0 - 1.2	140-150	20-21	45-50	10-15
4.5	1.0 - 1.2	1.0 - 1.5	140-150	22-23	40-50	15
6.0	1.2	1.2 - 1.5	170-185	24-26	40-50	15-20
9.0	1.2	1.2 - 1.5	320-340	32-34	40-50	15-20

FLAT FILLET WELDING LAP JOINT (THIN PLATE)

Metal thickness (mm)	Wire diameter (mm)	Welding current (A)	Welding voltage (V)	Welding speed (cm/min)	Gas Flow (L/min)
1.6	0.8 - 0.9	65-75	16-17	10	10-15
2.3	0.8 - 0.9	80-100	19-20	10	10-15
3.2	1.0-1.2	130-150	20-22	10-15	10-15
4.5	1.0-1.2	150-180	21-23	10-15	10-15

ANGLE JOINT (THIN PLATE)

Metal thickness (mm)	Wire diameter (mm)	Welding current (A)	Welding voltage (V)	Welding speed (cm/min)	Gas Flow (L/min)
0.2	0.8-0.9	60-70	16-17	10	10-15
1.2	0.8-0.9	80-90	18-19		
1.2	0.8-0.9	80 - 90	18-19	10	10-15
1.6	0.8-0.9	90-100	19-20		
1.6	0.8-0.9	90-100	19-20	10	10-15
2.3	0.8-0.9	100-130	20-22	10	10-15
2.3	1.0-1.2	120-150	21-23	10	10-15
3.2	1.0-1.2	150-180	23-24	10-15	10-15
4.5	1.2	200-250	25-28	10-15	10-15

FLAT ANGLE T-SHAPED WELDING

Metal thickness (mm)	Wire diameter (mm)	Welding current (A)	Welding voltage (V)	Welding speed (cm/min)	Gas Flow (L/min)
1.0	0.8 - 0.9	70-80	17-18	50-60	10-15
1.2	0.9-1.0	85-90	18-19	50-60	10-15
1.6	1.0-1.2	100-110	18-19.5	50-60	10-15
2.0	1.0-1.2	115-125	19.5-20	50-60	10-15
2.3	1.0-1.2	130-140	19.5-21	50-60	10-15
3.2	1.0-1.2	150-170	21-22	45-50	15-20
4.5	1.0 - 1.2	180-200	23-24	40-45	15-20
6	1.2	230-260	25-27	40-45	15-20
8.9	1.2-1.6	270-380	29-35	40-45	20-25
12	1.2-1.6	300-380	32-35	35-40	20-25

WELDING PITFALLS

The arc welding technique is an acquired skill and requires considerable practice before perfect results are obtained. The diagrams below will help to explain the pitfalls in your technique and how to overcome them.

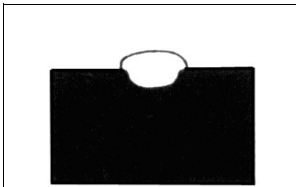

ARC TOO SHORT

This causes irregular masses of weld to be deposited, with slag contamination on an uneven surface.

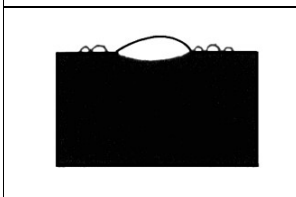

ARC TOO LONG

This causes poor penetration resulting in a weak weld with excessive spatter and porosity. Surface of the weld is rough and the arc makes a hissing sound

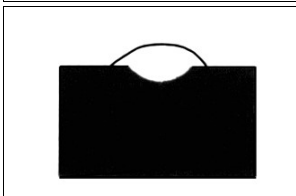

ELECTRODE MOVED TOO SLOWLY

This causes a very wide and heavy deposit which overlaps at the sides. It is wasteful both in terms of time and electrode use.

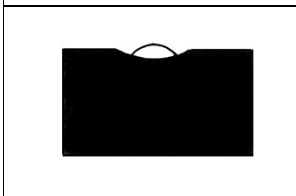

ELECTRODE MOVED TOO QUICKLY

This causes poor penetration with a 'stringy' and incomplete weld deposit. Slag is very hard to remove.

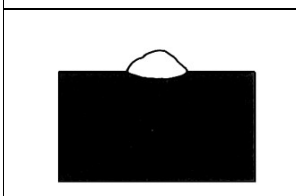

CURRENT TOO LOW

This causes poor penetration and causes the electrode to stick to the workpiece too readily. Also results in a very irregular and high weld deposit. Slag is very hard to remove.

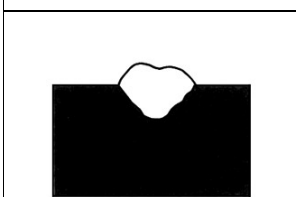

CURRENT TOO HIGH

This causes excessive penetration with spatter and deep pointed crater. It may also cause holes to be burned in the workpiece.

Burns electrodes very quickly.

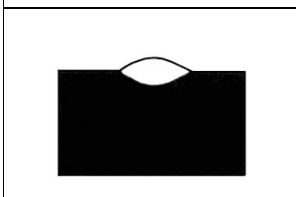

THE PERFECT WELD

With the correct combination of arc length, current regulation, inclination and speed of the electrode, you will, with practice, produce the perfect weld.

This should be regular with uniform ripples and no slag contamination. The arc will make a steady crackling sound.

MACHINE ERROR CODES

The machine error codes are displayed on the panel contact your nearest CLARKE dealer if repairs are required.

Error	Fault	Cause	Remedy
E05	Input over voltage	Input voltage too high	Check the voltage and correct
E06	Input under voltage	Input voltage too low	Check the voltage and correct
E15	Startup abnormal	1) Torch switch is on when power is on. 2) No no-load voltage 3) Current output	1) Check the torch switch 2) Replace the control board 3) Replace the driver board.
E17	Output over current	1) Over current 2) Current sensor failure 3) Signal wire broken 4) Control board broken	1) Repair the output cable 2) Repair the signal wire 3) Replace the current sensor 4) Replace the control board
E19	Overheat protection	1) Internal overheating (exceeding rated duty cycle/front or rear vents blocked). 2) Temperature relay failure. 3) Signal wire failure 4) control board failure	1) Check the fan and await cooling inside the power source. 2) Check connection of the temperature relay. 3) Replace control board 4) Replace temperature relay.
E40	Display cannot receive signal from control board	1) Communication harness loose or broken 2) Control board failure. 3) Display board failure.	1) Check communication harness 2) Replace control board 3) Replace display board
E41	Control board cannot receive signal from display board	1) Communication harness loose or broken 2) Control board failure. 3) Display board failure.	1) Check communication harness 2) Replace control board 3) Replace display board

TROUBLESHOOTING

Your welder has been designed to give long and trouble free service. If however, having followed the instructions in this booklet carefully you still encounter problems, the following points should help identify and resolve them.

DEFECT	CAUSES	SUGGESTIONS
Spark will not start	Bad clamp connection. Inverter PCB defective.	Check clamp connection. Contact your nearest CLARKE dealer.
No output voltage	Overheated machine	Wait for thermal cutout to be reset.
	Internal relay has failed.	Contact your nearest CLARKE dealer.
	Inverter PCB defective.	Contact your nearest CLARKE dealer.
Wrong output current	Current selector control is defective.	Contact your nearest CLARKE dealer.
	Low power supply voltage.	Have electrician check the mains supply.
Porosity of welds	Acid electrode on steel with high sulphur content. Electrode oscillates too much. Workpieces are too far apart. Workpiece being welded is cold.	Use basic electrode. Move edges to be welded closer together. Move slowly at the beginning.
Cracks in weld	Material being welded is dirty (e.g.oil, paint, rust, oxides, moisture). Incorrect current/voltage.	Clean workpiece before welding is an essential method of achieving neat weld beads. Also increase current output.
Poor penetration	Low welding current, high welding rate, Poor electrode inclination angle or too far from workpiece.	Ensure operating parameters are regulated and improve preparation of work pieces.
Profile defects	Welding parameters are incorrect. Pass rate is not related to operating parameter requirements. Electrode not inclined constantly while welding.	Follow basic and general welding principles.

DEFECT	CAUSES	SUGGESTIONS
High splatter	Electrode is too inclined. Contaminated wire or work-piece. Poorly matched current or voltage.	Make appropriate corrections.
Arc is unstable	Insufficient current.	Check condition of electrode and earth wire connection.
Electrode melts obliquely.	Electrode core is not centred. Magnetic blow phenomenon.	Replace electrode. Connect two earth wires to opposite sites of the work piece.
No response from welder.	Check fuses and power lead.	Replace fuses as necessary. If problem persists return welder to your local dealer.
		Check fuse size.
Welder does not feed wire.	Feed motor defective.	Return welder to your local dealer.
Feed motor running but no wire being fed from welder tip	Insufficient feed roller pressure.	Increase roller pressure.
	Burr on end of wire.	Re-cut wire square with no burr.
	Liner blocked or damaged.	Clean with compressed air or replace liner.
	Inferior wire	Use only good "clean" wire.
	Roller worn out.	Replace roller.
Wire welds itself to tip.	Wire feed speed too low.	Unscrew tip, cut wire and fit new tip. Increase wire speed before operating again
	Wrong size tip.	Fit correct size tip.
Wire feeds into 'birds nest' tangle.	Wire welded to tip	As previous and reduce feed roller pressure.
	Wire liner damaged preventing smooth operation.	Renew wire liner.
Loose coils of wire tangle around wire spool inside machine.	Locking knob too slack.	Tighten locking knob slightly. Do not over-tighten.

DEFECT	CAUSES	SUGGESTIONS
Erratic wire feed.	Tensioning knob too tight.	Loosen tensioning knob slightly.
	Tension roller worn.	Check and replace if necessary.
	Insufficient pressure on tension roller.	Increase pressure on tension roller Caution: DO NOT over-tighten.
	Wire dirty, rusty, damp or bent.	Re-cut wire and ensure it is clean.
	Liner partially blocked.	Clean with compressed air.
Poor quality welds.	Insufficient gas at weld area.	Check that gas is not being blown away by drafts and if so move to a more sheltered work area. If not, increase gas supply.
	Rusty, painted, damp, oil or greasy workpiece.	Ensure workpiece is clean and dry.
	Rusty/dirty wire.	Ensure wire is clean and dry.
	Poor earth contact.	Check earth clamp/workpiece connection.
Welder cuts out whilst in use.	Duty cycle exceeded (auto cut-out operates).	Allow welder to cool 15-30 mins before continuing. Note: If duty cycle is continually exceeded, damage to the welder may result and welder output is probably too small for application.

CARE AND MAINTENANCE



WARNING: ELECTRICITY CAN KILL - NEVER TOUCH LIVE ELECTRICAL COMPONENTS.

WARNING: DISCONNECT THE POWER SUPPLY BEFORE ALL INSPECTIONS AND MAINTENANCE. BEWARE HOT SURFACES.

The machine requires no maintenance other than the following guidelines. Cleaning at frequent intervals is advisable if the unit is operating in a very dusty environment. Avoid getting particles of metal inside the machine since they could cause short circuits and be alert to any unusual noises or smells.

1. Keep the louvres clean to avoid a build up of dirt inside the machine which can reduce machine output or become a hazard.
2. Check all cables periodically for good condition and security.
3. Always inspect the earth cable and torch hose before use, to ensure they are in perfect condition and that the earth clamp is clean and secured correctly to the cable.
4. Check the hose for security and damage.

Wire feed unit:

The feed roller / wire guide plays an important part in achieving consistent results. Periodically check the contact surfaces including the feed roller groove, removing any deposits. and checking the smoothness of rotation. Note that poor wire feeding can cause the welding arc to be unstable.

Check that the centre of the feed tube and the centre of the wire feed wheel groove line up exactly.

Torch:

Protect the torch hose assembly from mechanical wear. If the liner is blocked or damaged it must be replaced.

Contact tip:

The contact tip is a consumable item and must be replaced when the bore becomes enlarged or oval. The contact tip must be kept free from spatter to ensure an unimpeded flow of gas.

To keep the contact tip free from spatter, we recommend the use of anti-spatter spray (6000715) available from your CLARKE dealer.

Torch shroud:

The torch shroud must also be kept clean and free from spatter. Build-up of spatter inside the gas cup can cause a short circuit at the contact tip which will result in expensive machine repairs.

COMPONENT PARTS

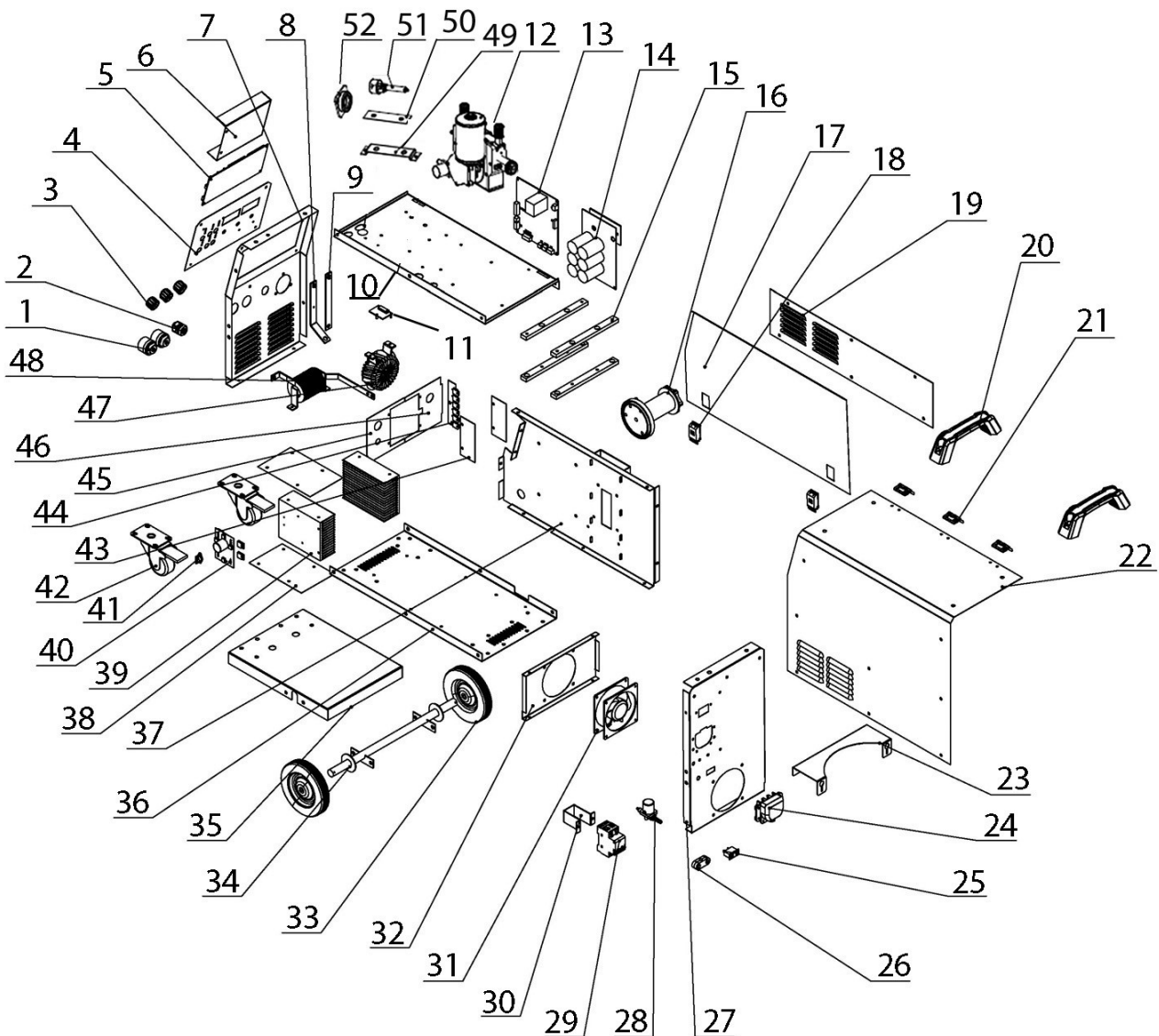

1	Coupling	19	Left side panel	37	Feed holding panel
2	Pull off connector	20	Handle	38	Air damper (U/D)
3	Potentiometer knobs	21	Hinge	39	Radiator
4	Control panel	22	Top cover	40	IGBT board
5	Display/PCB	23	Cylinder holder 1	41	Thermal cutout
6	Front cover case	24	Connection box	42	Castor wheel
7	Front panel	25	Heater connector	43	Air damper (L/R)
8	Pos connection strip	26	Cable clamp	44	FRD board
9	Neg connect strip	27	Rear panel	45	IGBT damper
10	Centre panel	28	Solenoid valve	46	FRD damper

11	Capacitor PCB	29	Circuit Breaker	47	Main Transformer
12	Wire feed assembly	30	Breaker holder	48	Output reactor
13	Main control board	31	Cooling fan	49	Feeder bracket
14	Power board	32	Fan holder panel	50	Insulation board
15	Insulation post	33	Wheel	51	Torch interface
16	Wire spool holder	34	Axle	52	Bracket
17	Wire feed door	35	Cylinder support		
18	Door latch	36	Bottom panel		

ARC ACTIVATED HEADSHIELDS

These highly popular head-shields activate instantly when the arc is struck and allow you to have both hands free when welding.

Model	Arc Activated	Grinding function	Solar Powered	Fixed Shade	Flip Up	Part Number
GWH4	X	X	X			6000706
GWH5	X	X	X			6000707
GWH6	X	X	X			6000708
GWH7	X	X	X			6000709
PG4	X	X	X			6000716
HS1				X	X	6000700
HSF1				X	X	6000705

GUARANTEE

This CLARKE product is guaranteed against faulty manufacture for a period of 12 months from the date of purchase. Please keep your receipt as proof of purchase.

This guarantee is invalid if the product is found to have been abused or tampered with in any way, or not used for the purpose for which it was intended.

Faulty goods should be returned to their place of purchase, no product can be returned to us without prior permission.

This guarantee does not effect your statutory rights.

CONSUMABLES

The following are some of the accessories available from your CLARKE dealer. Please quote the part numbers shown below:

Part	Description	Part number	Comment
Welding Wire Spools	Flux cored mild steel (mini spool) 0.9mm	8132110	Use for no gas welding
	Mild steel (mini) - 0.6mm	8132100	Use for gas welding
	Mild steel (mini) - 0.8mm	8132070	Use for gas welding
	Stainless Steel 0.8mm (mini spool)	8132090	
Welding Gas	CO ₂ (250g)	6000642	For welding mild steel
	CO ₂ (600g)	6000643	For welding mild steel
	Argon	6000661	For aluminium/stainless
	CO ₂ /Argon Mix	6000660	For welding stainless/ thin sheet mild steel
Welding Tips	0.6 mm (pack of 5)	8132260	
	0.8 mm (pack of 5)	8132270	
	1.0 mm (pack of 5)	8132275	
Arc Welding Rods	1.6 x 300mm	3050590	
	2.0 x 350mm	3050592	
	2.5 x 350mm	3050594	
	3.25 x 350mm	3050596	
Welding Rods	4.0 x 400mm E6013	3050598	
Welding Torch	Welding Torch Assembly (MMA/TIG)	6012232	
Regulators	Argon Gas Regulator	8134140	
	Single Gauge Regulator	8134160	
	Dual Gauge Argon Regulator	8134170	
	Dual Gauge CO ₂ Regulator	8134100	

A Gas Regulator, Arc Activated Headshields, Anti-spatter Spray, Swan Necks, Torch Shrouds and Torch Liner are also available from your CLARKE dealer or our parts division.

DECLARATION OF CONFORMITY - UK



Clarke[®]
INTERNATIONAL

Hemnall Street, Epping, Essex, CM16 4LG

DECLARATION OF CONFORMITY

This is an important document and should be retained.

We hereby declare that this product(s) complies with the following legislation:

The Ecodesign for Energy-Related Products Regulations 2010

The Electromagnetic Compatibility Regulations 2016

The Electrical Equipment (Safety) Regulations 2016

The Restriction of the Use of Certain Hazardous Substances in Electrical and Electronic Equipment Regulations 2012

The following standards have been applied to the product(s):

IEC 62321-4:2013/AMD1:2017, EN IEC 60974-10:2021, EN IEC 60974-7:2019, IEC 62321-7-1:2015, EN 50525-2-81:2011, IEC 62321-1:2013, IEC 62321-2:2013, IEC 62321-5:2013, IEC 62321-3-1:2013, IEC 62321-7-2:2017, IEC 60974-13:2021, IEC 62321-6:2015, IEC 62321-8:2017, EN 60974-11:2010, EN IEC 60974-1:2022+A11:2022, EN 60974-12:2011, IEC 62321:2013

The technical documentation required to demonstrate that the product(s) meet(s) the requirement(s) of the aforementioned legislation has been compiled and is available for inspection by the relevant enforcement authorities.

The UKCA mark was first applied in: 2024

Product Description: Multifunction Welder
Model Number(s): MIG270DV MULTI
Serial/Batch Number: Refer to product/packaging label
Date of Issue: 22/05/2024

Signed:

J.A Clarke

Director

DECLARATION OF CONFORMITY - CE



Clarke[®]
INTERNATIONAL

Fitzwilliam Hall, Fitzwilliam Place, Dublin 2

DECLARATION OF CONFORMITY

This is an important document and should be retained.

We hereby declare that this product(s) complies with the following legislation:

2009/125/EC	<i>Ecodesign Directive</i>
2014/30/EU	<i>Electromagnetic Compatibility Directive</i>
2014/35/EU	<i>Low Voltage Directive</i>
2011/65/EU	<i>Restriction of Hazardous Substances (RoHS) Directive</i>

The following standards have been applied to the product(s):

IEC 62321-4:2013/AMD1:2017, EN IEC 60974-10:2021, EN IEC 60974-7:2019, IEC 62321-7-1:2015, EN 50525-2-81:2011, IEC 62321-1:2013, IEC 62321-2:2013, IEC 62321-5:2013, IEC 62321-3-1:2013, IEC 62321-7-2:2017, IEC 60974-13:2021, IEC 62321-6:2015, IEC 62321-8:2017, EN 60974-11:2010, EN IEC 60974-1:2022+A11:2022, EN 60974-12:2011, IEC 62321:2013

The technical documentation required to demonstrate that the product(s) meet(s) the requirement(s) of the aforementioned legislation has been compiled and is available for inspection by the relevant enforcement authorities.

The CE mark was first applied in: 2024

Product Description:	Multifunction Welder
Model Number(s):	MIG270DV MULTI
Serial/Batch Number:	Refer to product/packaging label
Date of Issue:	22/05/2024

Signed:

J.A Clarke

Director

A SELECTION FROM THE VAST RANGE OF

Clarke®

QUALITY PRODUCTS



AIR COMPRESSORS
From DIY to industrial, Plus air tools, spray guns and accessories.

GENERATORS
Prime duty or emergency standby for business, home and leisure.

POWER WASHERS
Hot and cold, electric and engine driven - we have what you need

WELDERS
Mig, Arc, Tig and Spot. From DIY to auto/industrial.

METALWORKING
Drills, grinders and saws for DIY and professional use.

WOODWORKING
Saws, sanders, lathes, mortisers and dust extraction.

HYDRAULICS
Cranes, body repair kits, transmission jacks for all types of workshop use.

WATER PUMPS
Submersible, electric and engine driven for DIY, agriculture and industry.

POWERTOOLS
Angle grinders, cordless drill sets, saws and sanders.

STARTERS/CHARGERS
All sizes for car and commercial use.



PARTS & SERVICE: 0208 988 7400

Parts Enquiries
Parts@clarkeinternational.com

Servicing & Technical Enquiries
Service@clarkeinternational.com

SALES: UK 01992 565333 or Export 00 44 (0)1992 565335

Clarke® INTERNATIONAL Hemnall Street, Epping, Essex CM16 4LG
www.clarkeinternational.com